

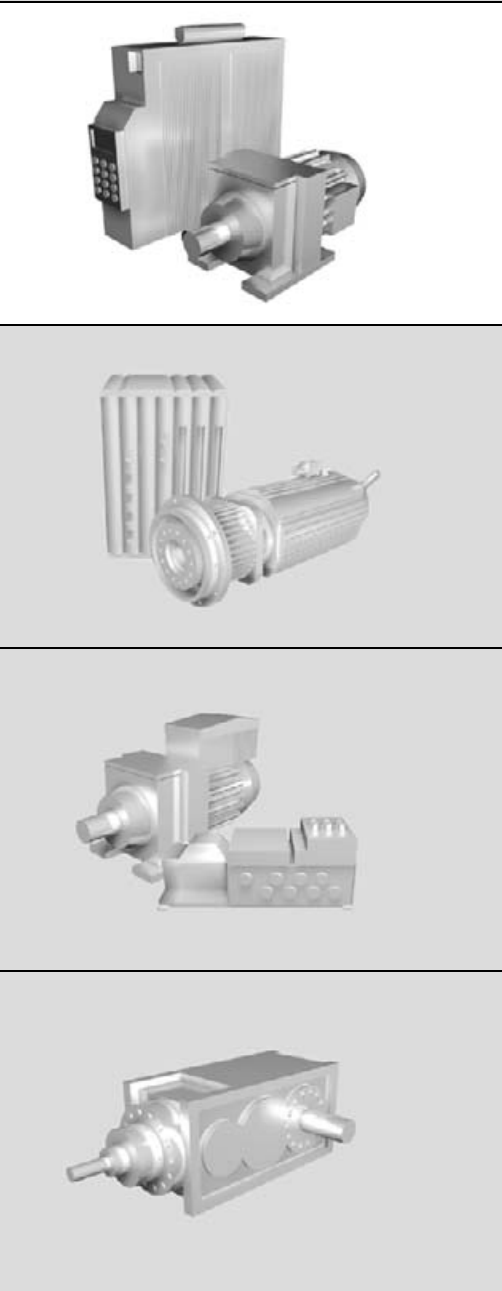

SEW
EURODRIVE



MOVITRAC[®] LT E

DA390000

Edition 10/2004
11308710 / EN

Catalog

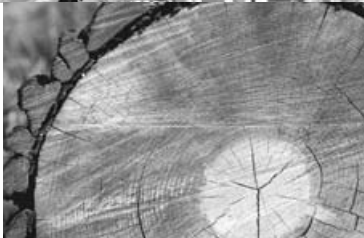



1	Important Notes on the Operating Instructions	4
1.1	Explanation of symbols	4
2	Safety Notes	6
3	Product overview	7
3.1	Technology	7
3.2	Mains supply compatibility	7
3.3	Markets and applications	7
3.4	Accessories available	7
4	General specifications	8
4.1	Input voltage ranges	8
4.2	Product designation	8
4.3	Output power and current ratings	9
4.4	Overload capability	11
4.5	Protection features	11
4.6	Conformance	11
4.7	Environmental	11
4.8	Physical dimensions	12
4.9	User interface	14
4.10	Signal terminals overview	15
4.11	Standard parameters	16
4.12	Extended parameters	17
4.13	P-19 Digital inputs function select	18
5	Accessories	19
5.1	Input filter	19
5.2	Line chokes	20
5.3	Output chokes	21
5.4	DIN rail mounting kit	22
5.5	Second analog input	22
5.6	Second relay output	23
5.7	PI Controller	24
6	Select a motor	25
6.1	Project planning flowchart	25
6.2	Inverter → motor combinations	26



1 Important Notes on the Operating Instructions

1.1 Explanation of symbols



Danger

Identifies information about practices or circumstances that will lead to personal injury or death, property damage, or economic loss.



Warning

Identifies information about practices or circumstances that may lead to personal injury or death, property damage, or economic loss.



Caution

Identifies information about practices or circumstances that may lead to property damage, or economic loss.



Note

Identifies information that is critical for successful application and understanding of the equipment.



Documentation reference

Operators are made aware of existing documentation, such as operating instructions, catalogs, data sheets.



Unless the information in the operating instructions is adhered to, it will be impossible to ensure:

- Trouble-free operation
- Fulfillment of any rights to claim under guarantee

Consequently, read the operating instructions before you start working with the unit!

The operating instructions contain important information about servicing. Therefore, keep the operating instructions close to the unit.



Application environment

The following applications are forbidden unless measures are expressly taken to make them possible:

- Use in explosion-proof areas
- Use in environments with harmful substances:
 - Oils
 - Acids
 - Gases
 - Vapors
 - Dust
 - Radiated interference
 - Other harmful environments
- Use subject to mechanical vibration and shock loads in excess of the requirements in EN 50178
- If the inverter performs safety functions which have to guarantee the protection of machinery and people

Waste disposal

Please follow the current instructions: dispose in accordance with the regulations in force:

- Electronics scrap (printed-circuit boards)
- Plastic (housing)
- Sheet metal
- Copper



2 Safety Notes

Installation and startup



- **Never install damaged products or take them into operation.** Please submit a complaint to the transport company immediately in the event of damage.
- **Installation, startup and service work** on the unit only by **trained personnel**. The personnel must be trained in the relevant aspects of accident prevention and must comply with the regulations in force (e.g. EN 60204, VBG 4, DIN-VDE 0100/0113/0160).
- Follow the **specific instructions** during **installation** and **startup** of the motor and the brake!
- Make sure that **preventive measures** and **protection devices** correspond to the **applicable regulations** (e.g. EN 60204 or EN 50178).
Grounding the unit is a necessary protective measure.
Overcurrent protection devices are a necessary protective measure.
- **The unit meets all requirements for reliable isolation** of power and electronics connections in accordance with EN 50178. **All connected circuits** must also **satisfy the requirements for reliable isolation** so as to guarantee reliable isolation.
- Take **suitable measures** to ensure that the connected **motor does not start up automatically when the inverter is switched on**. To do this, you can connect binary inputs DI01 through DI03 to GND.
- Connection to the frequency inverter output is only permitted in size 0S, 0M and 0L when the output stage is inhibited.

Operation and servicing



- **Disconnect the unit from the supply system** prior to **removing the protective cover**. **Dangerous voltages** may still be present for up to **10 minutes after mains disconnection**.
- The unit has **IP 00** enclosure with the **protective cover removed**. **Dangerous voltages** are present at all subassemblies except for the control electronics. Keep the unit closed during operation.



- **Dangerous voltages** are present at the **output terminals** and the **cables and motor terminals connected to them when the unit is switched on**. Dangerous voltages may also be present when the unit is inhibited and the motor at a standstill.
- The unit is **not** necessarily **deenergized** when the **LEDs and the 7-segment display are off**.
- **Safety functions inside the unit** or a **mechanical blockage** may cause the **motor to stop**. The **removal of the source of the malfunction** or a **reset** can result in an **automatic restart of the drive**. If, for safety reasons, this is **not permissible** for the driven machine, **disconnect the unit from the supply system** before correcting the fault.



3 Product overview

3.1 Technology

The MOVITRAC® LT E range consists of a series of products in two physical sizes designed to provide cost-effective, easy-to-use drives for 3-phase induction motors in the power range 0.37 kW to 4.0 kW (0.5 hp to 5 hp).

The MOVITRAC® LT E employs open loop voltage and frequency control to regulate the speed of the motor. Digital control is combined with the latest IGBT power semiconductor technology to give a compact, robust solution for general purpose drive applications. The product is designed for ease of use and ease of installation, together with simple programming and commissioning thereby minimising the overall applied cost of a drive solution.

3.2 Mains supply compatibility

The MOVITRAC® LT E is designed for direct on-line connection to world wide supplies. The 220 V single phase unit operates on 220 ... 240 V 1 or 3-phase mains, whereas the 380 V 3-phase unit operates on 380 ... 480 V 3-phase mains.

3.3 Markets and applications

The MOVITRAC® LT E product range is aimed at a broad market where general motor speed control is required. Real benefits are offered to both low volume end users and to OEM customers, where the ease of use and the innovative mechanical design significantly reduce commissioning time.

Typical applications are:

- Pumps in the water supply industry, paper industry and sewage systems
- Fan controllers in air conditioning systems, energy saving applications and refrigeration systems
- Compressors in refrigeration systems and compressed air supply systems
- Conveyor belts

The simple but powerful features make the MOVITRAC® LT E, in combination with the available accessories, suitable for a wide range of applications.

3.4 Accessories available

- External EMC filter
- Line choke to reduce supply harmonic distortion and offer additional protection to the drive
- Output choke to improve quality of output waveform and for long motor cables
- PI controller for simple feedback control systems
- Second analog input to switch between two references
- Second relay output for a second programmable relay output
- DIN rail mounting kit



General specifications

Input voltage ranges

4 General specifications

4.1 Input voltage ranges

Depending upon model and power rating, the drives are designed for direct connection to the following supplies:

MOVITRAC® LT E sizes 1, 2 (220 V):

220 V ... 240 V ± 10 %, 1 ph (3 ph*), 50 ... 60 Hz ± 5 %



*It is also possible to connect 1-phase MOVITRAC® LT to 2-phases of a 220 ... 240 V 3-phase mains.

MOVITRAC® LT E sizes 1, 2 (400 V):

380 V ... 480 V ± 10 %, 3 ph, 50 ... 60 Hz ± 5 %

Products used with a 3-phase supply are designed for a maximum supply imbalance of 3 % between phases. For input supplies which have a supply imbalance greater than 3 % (typically the Indian subcontinent and parts of Asia Pacific including China) we recommend that input chokes are used.

4.2 Product designation

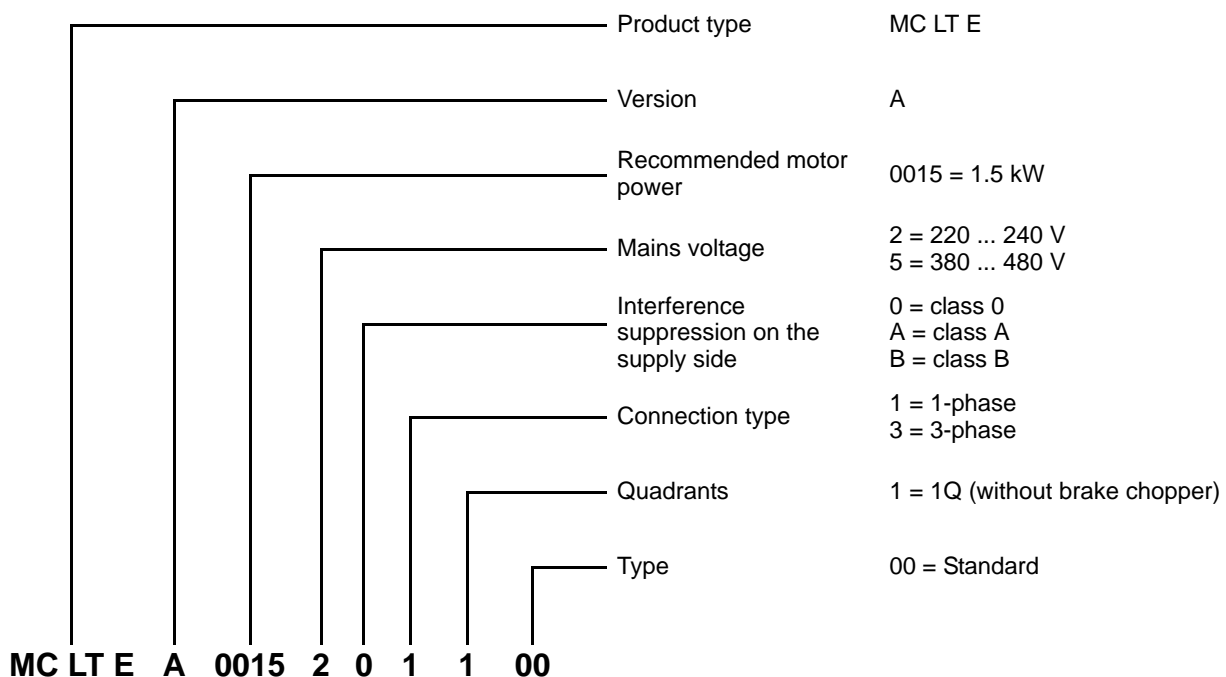



4.3 Output power and current ratings

1-phase (3-phase¹⁾) system AC 220 ... 240 V / 0.37 ... 2.2 kW

MOVITRAC® MC LT E A...	0004 201 1 00	0008 201 1 00	0015 201 1 00	0022 201 1 00	
Part number	828 360 5	828 361 3	828 362 1	828 364 8	
Interference suppression according to EMC EN 61000-3	0				
INPUT					
Supply voltage	V _{mains}	1 × AC 220 ... 240 V ± 10 %			
Supply frequency	f _{mains}	50 / 60 Hz ± 10 %			
Recommended motor power	[kW]	0.37	0.75	1.5	2.2
	[hp]	0.5	1.0	2.0	3.0
OUTPUT					
Output current	[A]	2.3	4.3	7.0	10.5
Motor cable size Cu 75C	[mm ²]	1.0			1.5
	[AWG]	17			16
Max motor cable length (unshielded cable @ 32 kHz)	[m]	50	50	50	150
GENERAL					
Max. ambient temperature [°C]	8 kHz	50	50	50	50
	16 kHz	50	40	40	40
	32 kHz	50	30	30	30
Dimensions W × H × D	[mm]	80 × 155 × 130			100 × 260 × 175
	[in]	3.15 × 6.10 × 5.12			3.94 × 10.23 × 6.89
Size		1	1	1	2

MOVITRAC® MC LT E A...	0004 2B1 1 00	0008 2B1 1 00	0015 2B1 1 00	0022 2B1 1 00	
Part number	828 365 6	828 366 4	828 367 2	828 368 0	
Interference suppression according to EMC EN 61000-3	B (integrated EMC filter)				
INPUT					
Supply voltage	V _{mains}	1 × AC 220 ... 240 V ± 10 %			
Supply frequency	f _{mains}	50 / 60 Hz ± 10 %			
Recommended motor power	[kW]	0.37	0.75	1.5	2.2
	[hp]	0.5	1.0	2.0	3.0
OUTPUT					
Output current	[A]	2.3	4.3	7.0	10.5
Motor cable size Cu 75C	[mm ²]	1.0			1.5
	[AWG]	17			16
Max motor cable length (unshielded cable @ 32 kHz)	[m]	50	50	50	150
GENERAL					
Max. ambient temperature [°C]	8 kHz	50	50	50	50
	16 kHz	40	40	40	40
	32 kHz	30	30	30	30
Dimensions W × H × D	[mm]	80 × 155 × 130			100 × 260 × 175
	[in]	3.15 × 6.10 × 5.12			3.94 × 10.23 × 6.89
Size		1	1	1	2

1) It is also possible to connect 1-phase MOVITRAC® LT E to 2-phases of a 220 ... 240 V 3-phase mains.



General specifications

Output power and current ratings

3-phase system AC 380 ... 480 V / 0.75 ... 4.0 kW

MOVITRAC® MC LT E A...		0008 503 1 00	0015 503 1 00	0022 503 1 00	0040 503 1 00
Part number		828 369 9	828 370 2	828 371 0	828 372 9
Interference suppression according to EMC EN 61000-3		0			
INPUT					
Supply voltage	V_{mains}	3 × AC 380 ... 480 V ± 10 %			
Supply frequency	f_{mains}	50 / 60 Hz ± 10 %			
Recommended motor power	[kW]	0.75	1.5	2.2	4.0
	[hp]	1.0	2.0	3.0	5.0
OUTPUT					
Output current	[A]	2.2	4.1	5.8	9.5
GENERAL					
Motor cable size Cu 75C	[mm ²]	1.0			1.5
	[AWG]	17			16
Max motor cable length (unshielded cable @ 32 kHz)	[m]	15	15	150	150
Max. ambient temperature [°C]	8 kHz	50	50	50	50
	16 kHz	40	40	40	40
	32 kHz	30	30	30	30
Dimensions W × H × D	[mm]	80 × 155 × 130		100 × 260 × 175	
	[in]	3.15 × 6.10 × 5.12		3.94 × 10.23 × 6.89	
Size		1	1	2	2

MOVITRAC® MC LT E A...		0008 5A3 1 00	0015 5A3 1 00	0022 5A3 1 00	0040 5A3 1 00
Part number		828 373 7	828 374 5	828 375 3	828 376 1
Interference suppression according to EMC EN 61000-3		A (integrated EMC filter)			
INPUT					
Supply voltage	V_{mains}	3 × AC 380 ... 480 V ± 10 %			
Supply frequency	f_{mains}	50 / 60 Hz ± 10 %			
Recommended motor power	[kW]	0.75	1.5	2.2	4.0
	[hp]	1.0	2.0	3.0	5.0
OUTPUT					
Output current	[A]	2.2	4.1	5.8	9.5
GENERAL					
Motor cable size Cu 75C	[mm ²]	1.0			1.5
	[AWG]	17			16
Max motor cable length (unshielded cable @ 32 kHz)	[m]	15	15	150	150
Max. ambient temperature [°C]	8 kHz	50	50	50	50
	16 kHz	40	40	40	40
	32 kHz	30	30	30	30
Dimensions W × H × D	[mm]	80 × 155 × 130		100 × 260 × 175	
	[in]	3.15 × 6.10 × 5.12		3.94 × 10.23 × 6.89	
Size		1	1	2	2



4.4 Overload capability

All MOVITRAC® LT E have a possible overload of:

- 150 % for 60 seconds
- 175 % for 2 seconds

4.5 Protection features

The range of drives can detect and shut down in the event of the following fault conditions arising:

- Output phase - output phase short circuit
- Output phase - earth short circuit
- Output phase over-current trip
- Output current thermal overload ($I \times t$)
- Heatsink thermal overload (trip @ 95 °C)
- DC link over voltage
- DC link under voltage
- External (thermistor) trip

4.6 Conformance

All products conform to the following international standards:

- CE marked for low voltage directive
- IEC 664-1 Insulation co-ordination within low voltage systems
- UL 508C Power conversion equipment
- EN 61800-3 Adjustable Speed electrical power drive systems - Part 3
- EN 61000-6 / -2, -3, -4 Generic immunity/ Emission standards (EMC)
- Enclosure protection level according to NEMA 250, EN 60529
- Flammability rating according to UL 94
- C-Tick
- cUL

4.7 Environmental

Ambient temperature range operational	0 ... 50 °C @ 8 kHz PWM frequency
Ambient temperature range storage	-40 °C ... 60 °C
Max. altitude for rated operation	1000 m
Derating above 1000 m	1 % / 100 m to 2000 m max.
Relative humidity	<95 % (non condensing)
Protection rating	IP20, NEMA 0



4.8 Physical dimensions

Dimension	Size 1	Size 2
Length / mm (in)	155 (6.10)	260 (10.23)
Width / mm (in)	80 (3.15)	100 (3.94)
Depth / mm (in)	130 (5.11)	175 (6.89)
Weight / kg (lb)	1.1 (2.42)	2.6 (5.73)
A / mm (in)	72 (2.83)	92 (3.62)
B / mm (in)	4 (0.16)	
C / mm (in)	25 (0.98)	
D / mm (in)	105 (4.13)	210 (8.27)
Fixings	2 × M4	
Power terminal torque settings	1 Nm	1 Nm
	8.85 lb.in	8.85 lb.in
Control terminal torque settings	0.5 Nm	0.5 Nm
	4.43 lb.in	4.43 lb.in

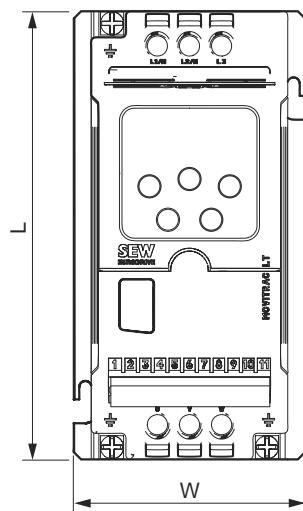

54769AXX

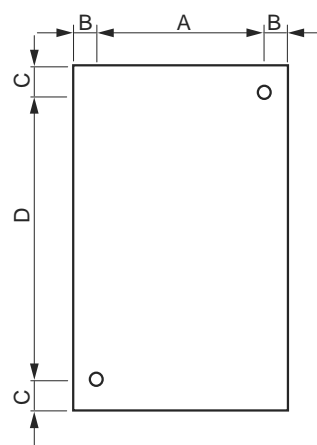

54770AXX

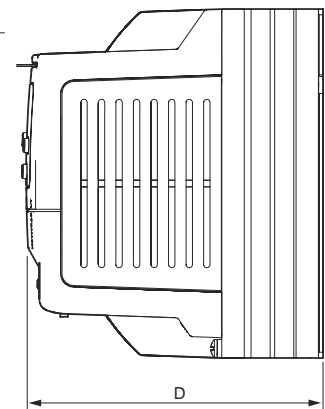

54781AXX



**Dimensions for
non vented metal
housing**

Drive power rating		Sealed unit					
		W		H		D	
		[mm]	[in]	[mm]	[in]	[mm]	[in]
Size 1	0.37 kW 200 V	200	7.87	250	9.84	200	7.87
Size 1	0.75 kW 200 V / 400 V	250	9.84	300	11.81	200	7.87
Size 1	1.5 kW 200 V / 400 V	300	11.81	400	15.75	250	9.84
Size 2	2.2 kW 400 V	300	11.81	400	15.75	300	11.81
Size 2	2.2 kW 200V / 4.0 kW 400 V	450	17.71	600	23.62	300	11.81

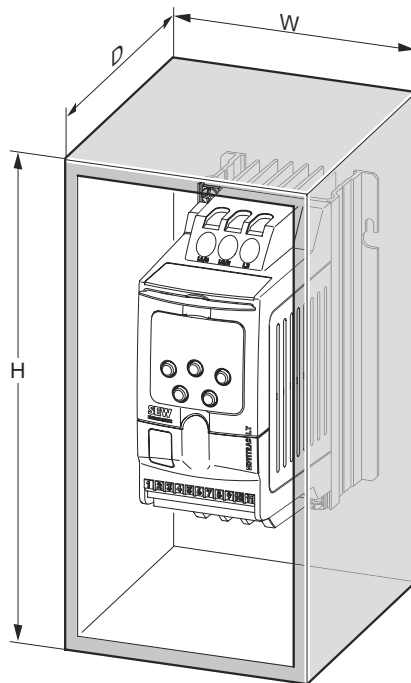

Figure 1: Housing

54784AXX



4.9 User interface

Keypad

Each MOVITRAC® LT E has an integrated keypad as standard, allowing drive operation and set up without any additional equipment.

The keypad consists of 5 keys with the following functions:

Start / Run:	Enable running of motor
Stop / Reset:	Stop motor / Reset trip
Navigate:	Press and hold to enter / exit parameter edit mode
Up:	Increase Parameter / Value
Down:	Decrease Parameter / Value

The Start / Stop buttons on the keypad are disabled when the parameters have their factory default settings. To enable the operation of the Start / Stop buttons on the keypad, set P-12 to 1 or 2 (see chapter 4.11, "Standard parameters").

The Navigate key alone is used to gain access to the parameter edit menu. Pressing and holding this key (> 1 sec) allows the user to toggle between the parameter edit menu and the real time display (where the drive operating status / running speed is displayed). By pressing this key (< 1 sec) the user is able to toggle between the operating speed and operating current during drive operation.

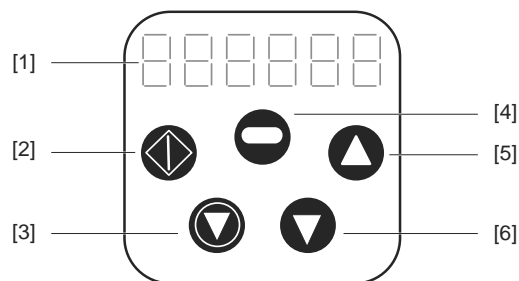

54787AXX

[1]	Display
[2]	Start
[3]	Stop / Reset
[4]	Navigate
[5]	Up
[6]	Down

Display

A standard 6-digit, 7-segment display is integrated into each drive to allow drive operation to be monitored and parameters to be set.



4.10 Signal terminals overview

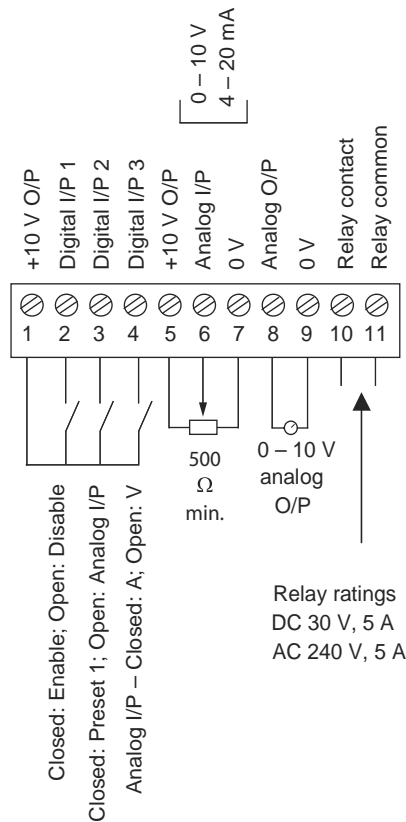

54790AXX

The signal terminal block has the following signal connections:

Terminal no.	Description	Connection
1	+10 V ref out	Ref. to activate DI1 ... DI3
2	Digital input 1	Connect to +8 V ... 30 V DC to activate
3	Digital input 2	Connect to +8 V ... 30 V DC to activate
4	Digital input 3	Connect to +8 V ... 30 V DC to activate
5	+10 V ref out	10 V ref for analog input (pot supply +) (10 mA max)
6	Analog input (12 bit)	0 ... 10 V (4 ... 20 mA when Iref enabled)
7	0 V common	0 V ref for analog input (pot supply -)
8	Analog output (10 bit)	0 ... 10 V, 10 V / 20 mA digital programmed
9	0 V common	0 V ref for analog output
10	Relay N.O	N.O. relay contact (250 V AC / 30 V DC @ 5A)
11	Relay Common	N.O. relay contact (250 V AC / 30 V DC @ 5A)



All digital inputs activated by input voltage in range +8 V ... 30 V
i.e. +28 V compatible



4.11 Standard parameters

Par	Description	Range	Default
P-01 ¹⁾	Max speed limit (Hz or rpm)	max. 500 Hz	50 Hz
P-02 ¹⁾	Min speed limit (Hz or rpm)	0 ... P-01 (max. 500 Hz)	0 Hz
P-03	Accel ramp time (s)	0.0 s ... 3000 s	5 s
P-04	Decel ramp time (s)	0.0 s ... 3000 s	5 s
P-05	Stop mode select	Ramp to stop / coast to stop	Ramp to stop
P-06	V/F characteristic	0 Constant torque V/f	0 (V/f)
		1 Pump-Fan V/f ²	
P-07	Rapid decel ramp time	0.0 s ... 25 s (disabled when 0.0 s)	0.0 s
P-08	Motor rated current limit	0 to current rating of drive (Amps)	Rated I-Drive
P-09	Motor rated frequency	25 ... 500 Hz	50 Hz 60 Hz (USA & Canada only)
P-10	Motor rated speed	0 ... 60,000 rpm	0
P-11	Voltage boost	0 ... 25 % of max output voltage	3 %
P-12	Terminal / Keypad control of drive	0 Terminal control	0 (terminal)
		1 Keypad control (fwd only)	
		2 Keypad control (fwd / rev to toggle between fwd and rev using start button)	
P-13	Trip log	Last four trips stored	no fault
P-14	Extended menu access code	0 ... 9999	0

1) If the motor rated speed in rpm has been entered into P-10, parameters P-01, P-02, P-20 ... P-23, P-27 and P-28 are in rpm.



4.12 Extended parameters

Par	Description	Range	Default	
P-15	Motor rated voltage	40 V upto mains voltage	0 (motor voltage = mains voltage)	
P-16	Analog input V / mA	0-10 V, 4-20 mA, 0-20 mA, 20-4 mA, 10-0 V	0-10 V	
P-17	Effective switching frequency	8, 16, 32 kHz	8 kHz	
P-18	Relay output function	0	MOVITRAC® LT E Enabled	1 Drive healthy
		1	Drive healthy (not tripped)	
		2	Motor at set speed	
		3	Motor at zero speed (<5 % of P-09)	
		4	Motor at max speed (P-01)	
		5	Motor current overload	
P-19	Digital inputs function select	0 to 12, See table in chapter 4.13	0	
P-20 ¹⁾	Preset speed 1	P-02 (min) ... P-01 (max)	50 Hz	
P-21 ¹⁾	Preset speed 2	P-02 (min) ... P-01 (max)	0 Hz	
P-22 ¹⁾	Preset speed 3	P-02 (min) ... P-01 (max)	0 Hz	
P-23 ¹⁾	Preset speed 4	P-02 (min) ... P-01 (max)	0 Hz	
P-24	Not used			
P-25	Analog output function select	0	Motor speed (analog)	0
		1	Motor current (analog)	
		2	Drive enabled (digital)	
		3	Motor at set speed (digital)	
P-26	V/F characteristic adjustment factor	20 % ... 250 % (Used together with P29.)	100 %	
P-27 ¹⁾	Skip freq / speed	P-02 (min) ... P-01 (max)	0 Hz	
P-28 ¹⁾	Skip freq / speed band	0 upto 100% of base freq (P-09)	0 Hz	
P-29	V/F characteristic adjustment frequency	0 Hz upto base frequency (P-09). Function disabled when set to 0. (Used together with P26.)	0 Hz	
P-30	Drive start mode	Edge-r	requires the run signal once after trip or power down	Auto 0
	Drive start mode	Auto-0	enables whenever a run signal is applied	
	Drive start mode	Auto-1 ... 4	Inverter will attempt to restart after a trip 1 ... 4 times	
P-31	DC injection voltage	0.1 ... 20 %	10 %	
P-32	DC injection braking time(s)	0 ... 250 s	0 s	
P-33	DC injection on enable	0	Disable	0
		1	Enable	0
P-34	Not used			
P-35	Analog input scaling factor	1 % ... 500 %	100 %	
P-36	Not used			
P-37	Access code definition	0 ... 9999	101	
P-38	Parameter access lock	0	All parameters can be changed and are auto- saved on power down	0 (write access and auto-save enabled)
		1	Parameter changes not saved on power down	
		2	Parameter read-only access. No changes allowed.	
P-39	Hours run meter	0 ... 99999 hours	Read only	
P-40	Drive identifier software checksum	0000 ... FFFF (hex) Drive rating / software version	Read only	

1) If the motor rated speed in rpm has been entered into P-10, parameters P-01, P-02, P-20 ... P-23, P-27 and P-28 are in rpm.



4.13 P-19 Digital inputs function select

The functionality of the digital inputs within the MOVITRAC® LT E is user programmable, allowing the user to select the functions required for the application.

Options include:

- selection between preset speeds
- analog input (voltage / current)
- external thermistor input
- forward / reverse
- push-button operation

The following table defines the functions of the digital inputs depending on the value of parameter P-19 (Digital input function select).

P-19	Digital input 1 function	Digital input 2 function	Digital input 3 function
0	Open : Stop (Disable) Closed : Run (Enable)	Open : Analog input Closed : Speed Preset 1	Volts / Current analog input
1	Open : Stop (Disable) Closed : Run (Enable)	Open : Analog input Closed : Speed Preset 1/2 (Digital input 3 selects)	Open : Speed Preset 1 Closed : Speed Preset 2
2	Open : Stop (Disable) Closed : Run (Enable)	Digital input 2 : open \ Digital input 3 : open / Digital input 2 : closed \ Digital input 3 : closed / Digital input 2 : open \ Digital input 3 : closed / Digital input 2 : closed \ Digital input 3 : closed /	→ Selects Speed Preset 1 → Selects Speed Preset 2 → Selects Speed Preset 3 → Selects Speed Preset 4
3	Open : Stop (Disable) Closed : Run (Enable)	External trip input Open : trip, Closed : OK	Open : Analog Input Closed : Speed Preset 1
4	Open : Stop (Disable) Closed : Run (Enable)	Open : Forward Closed : Reverse	Open : Analog Input Closed : Speed Preset 1
5	Open : Stop (Disable) Closed : Fwd Enable	Open : Stop (Disable) Closed : Reverse Enable	Open : Analog Input Closed : Speed Preset 1
6	Open : Stop (Disable) Closed : Run (Enable)	Open : Forward Closed : Reverse	External trip input Open : trip, Closed : OK
7	Open : Stop (Disable) Closed : Fwd Enable	Open : Stop (Disable) Closed : Reverse Enable	External trip input Open : trip, Closed : OK
8	Open : Stop (Disable) Closed : Run (Enable)	Open : Forward Closed : Reverse	Open : Speed Preset 1 Closed : Speed Preset 2
9	Open : Stop (Disable) Closed : Fwd Enable	Open : Stop (Disable) Closed : Reverse Enable	Open : Speed Preset 1 Closed : Speed Preset 2
10	Normally Open (N.O.) Momentarily Close to run	Normally Closed (N.C.) Momentarily Open to stop	Open : Analog Input Closed : Speed Preset 1
11	Normally Open (N.O.) Push to run forwards	Normally Closed (N.C.) Momentarily Open to stop	Normally Open (N.O.) Push to run reverse
12	Open : Stop (Disable) Closed : Fwd Enable	Closed to run Open to activate fast stop	Open : Analog Input Closed : Speed Preset 1



5 Accessories

5.1 Input filter

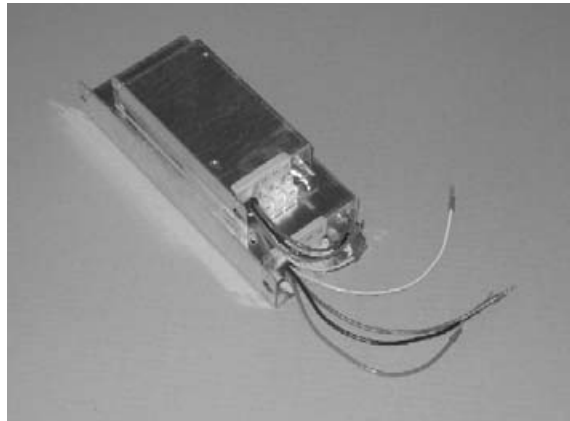

54800AXX

The MOVITRAC[®] LT E is available with or without an internal EMC filter. The filter option is used where it is required to meet conducted emission standard EN61000-6-3/4. Please note that all MOVITRAC[®] LT E inherently comply with the EMC radiated emission standards (EN61000-6-2) when good wiring practice is employed.

The internal EMC filters are specified as follows:

- 220 ... 240 V MOVITRAC[®] LT E with internal filter meet EN61000-6-3 Domestic (Class B)
- 380 ... 480 V MOVITRAC[®] LT E with internal filter meet EN61000-6-4 Industrial (Class A)

All relevant part numbers are detailed in chapter 4.2, "Product designation".

The external EMC filters can be used for more demanding applications where, for example, the 480 V drive is required to meet domestic (class B) emission requirements. They are specified as follows:

MOVITRAC [®] LT E size	1	1	2	2
Input filter model	NF LT 2B1 010	NF LT 5B3 006	NF LT 2B1 016	NF LT 5B3 016
Part number	18201571	18201601	18201598	18201628
Supply voltage [V] ± 10%	220 ... 240	220 ... 480	220 ... 240	220 ... 480
Phases	1	3	1	3
Max output current [A]	10	6	16	16



5.2 Line chokes

Line chokes reduce supply harmonic distortion and protect MOVITRAC® LT E units against harmful supply disturbances. They are also used to reduce the effects of the MOVITRAC® LT E upon supply harmonic distortion.



54801AXX

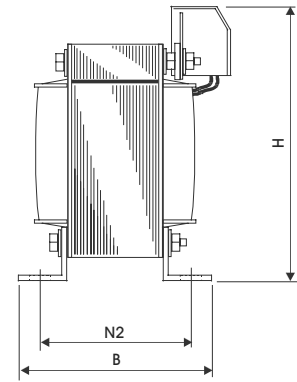
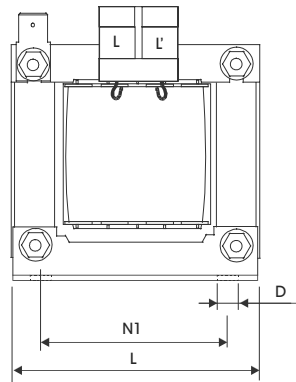

54886AXX

Line chokes are also used to protect the power input circuits of the MOVITRAC® LT E against voltage spikes which might originate from lightning strikes or other equipment on the same supply.

Type	Part number	MOVITRAC® LT E Size	Rated voltage [V]	Phase	Rated current [A]	Inductance / limb [mH]
ND LT 010 290 21	18201644	1	<230	1	10	2.9
ND LT 025 110 21	18201652	2	<230	1	25	1.1
ND LT 006 480 53	18201660	1	<500	3	6	4.8
ND LT 010 290 53	18201679	2	<500	3	10	2.9

Type	L		B		H		N1		N2		D		Mass	
	[mm]	[in]	[mm]	[in]	[mm]	[in]	[mm]	[in]	[mm]	[in]	[mm]	[in]	[kg]	[lb]
ND LT 010 290 21	66	2.60	80	3.15	70	2.76	50	1.97	51	2.00	5 × 8	0.2 × 0.31	0.8	1.76
ND LT 025 110 21	85	3.35	95	3.74	95	3.74	64	2.52	59	2.32	5 × 8	0.2 × 0.31	1.8	3.97
ND LT 006 480 53	95	3.74	56	2.20	107	4.21	56	2.20	43	1.69	5 × 9	0.2 × 0.35	1.3	2.87
ND LT 010 290 53	125	4.92	71	2.80	127	5.00	100	3.94	55	2.17	5 × 8	0.2 × 0.31	2.5	5.51



5.3 Output chokes

Output chokes improve the quality of the output waveform.



54803AXX

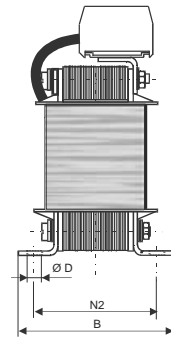
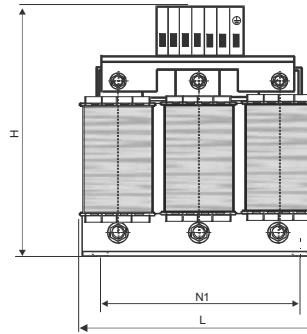

54887AXX

MOVITRAC® LT E, like the majority of other inverter drives, have unfiltered outputs. In the majority of applications this will give satisfactory performance, however, in a small number of applications output filtering is strongly recommended to improve system functionality, reliability and lifetime.

These applications include:

- High capacitance motor cables
- Long motor cables, up to 300 m
- Multiple motors connected in parallel
- Motors without inverter grade insulation

A range of high quality output chokes are available for MOVITRAC® LT E with the following key features:

- Limits output voltage gradient
- Limits transient over voltages at motor terminals, typically <1000 V
- Suppression of mains conducted interference in lower frequency ranges
- Compensation of capacitive load currents
- Reduction of RFI emissions of the motor cable
- Reduction of motor losses and audible noise caused by ripple

Type	Part number	MOVITRAC® LT E Size	Rated voltage [V]	Rated current [A]	Inductance / limb [mH]
HD LT 008 200 53	18201695	1	500 V	8	2
HD LT 012 130 53	18201709	2	500 V	12	1.3

Type	L		B		H		N1		N2		D		Mass	
	[mm]	[in]	[mm]	[in]	[mm]	[in]	[mm]	[in]	[mm]	[in]	[mm]	[in]	[kg]	[lb]
HD LT 008 200 53	100	3.94	90	3.54	75	2.95	60	2.37	48	1.89	4	0.16	1.5	3.31
HD LT 012 130 53	125	4.92	115	4.52	85	3.35	100	3.94	55	2.17	5	0.2	3.0	6.61



5.4 DIN rail mounting kit

A mounting kit is available to fit the MOVITRAC® LT E onto a DIN rail.

Type	Part number	MOVITRAC® LT E Size
FH LT DINHS 01	18201776	1
FH LT DINHS 02	18201784	2



54888AXX

5.5 Second analog input

Type	Part number
OB LT 2ANIN	18201547

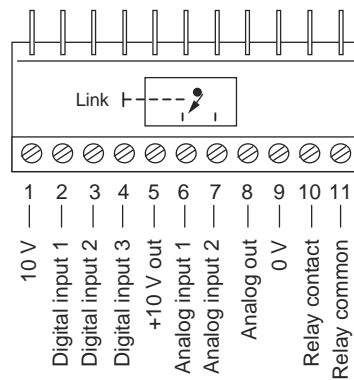

54813AXX

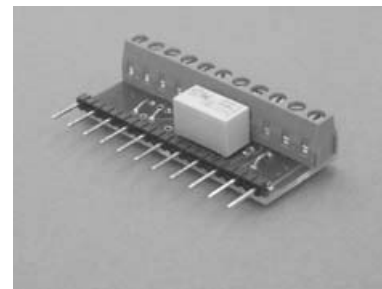

54816AXX

This board allows automatic switching between 2 analog references.

Specification

Analog input 1		± 10 V DC or 4 ... 20 mA
Analog input 2		± 10 V DC or 4 ... 20 mA
Conformity		IP00, UL94V-0
Environmental		-10 ... +50 °C
Dimensions	[mm]	56 × 24 (not pins) × 14
	[in]	2.20 × 0.98 (not pins) × 0.56



5.6 Second relay output

Type	Part number
OB LT 2ROUT	18201555

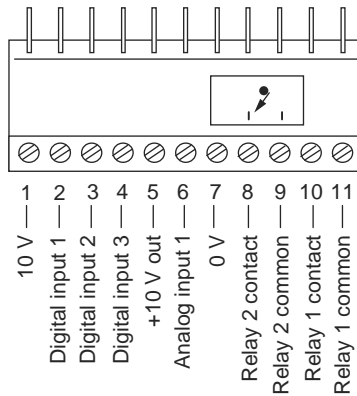

54929AXX

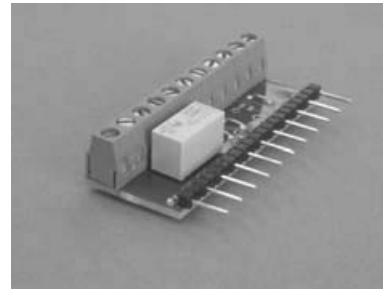

54821AXX

This board provides a programmable second relay output which is controlled using P-25.

The second relay output is controlled using MOVITRAC® LT E Parameter 25:

- P-25 = 2: Relay 2 contacts closed when inverter enabled
- P-25 = 3: Relay 2 contacts closed when inverter at set (requested) speed

Specification

Max. relay switching voltage	250 V AC / 220 V DC	
Max. relay switching current	1 A	
Conformity	IP00, UL94V-0	
Environmental	-10 ... +50 °C	
Dimensions	[mm]	56 × 24 (not pins) × 14
	[in]	2.20 × 0.98 (not pins) × 0.56



5.7 PI Controller

Type	Part number
OB LT PICON	18201563

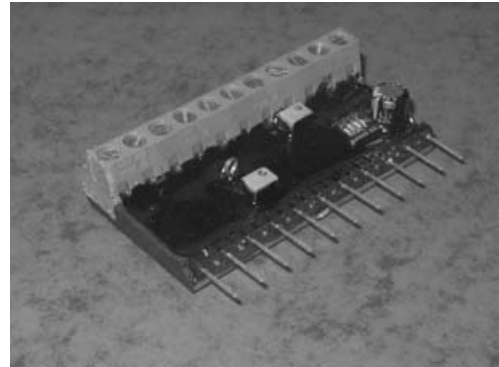
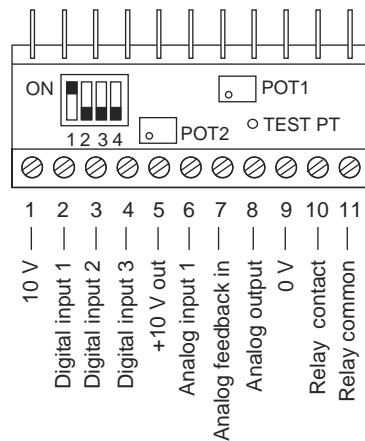

54835AXX

54832AXX

Key benefits:

- Small physical size
- Potted for robustness and environmental protection
- Minimal setup for quick and easy commissioning
 - integral gain set by 2 switches
 - proportional gain set by potentiometer
- Built in reference potentiometer for convenient setup for feedback reference point.

Specification

Rated reference input	$\pm 10 \text{ V}$ or $4 \dots 20 \text{ mA}$	
Proportional gain range	0.2 ... 30	
Rated feedback input	$\pm 10 \text{ V}$ or $4 \dots 20 \text{ mA}$	
Conformity	IP00, UL90V-0	
Environmental	$-10 \dots +50 \text{ }^\circ\text{C}$	
Dimensions	[mm]	56×33 (not pins) $\times 16$
	[in]	$2.20 \times 1.31 \times 0.64$



6 Select a motor

6.1 Project planning flowchart

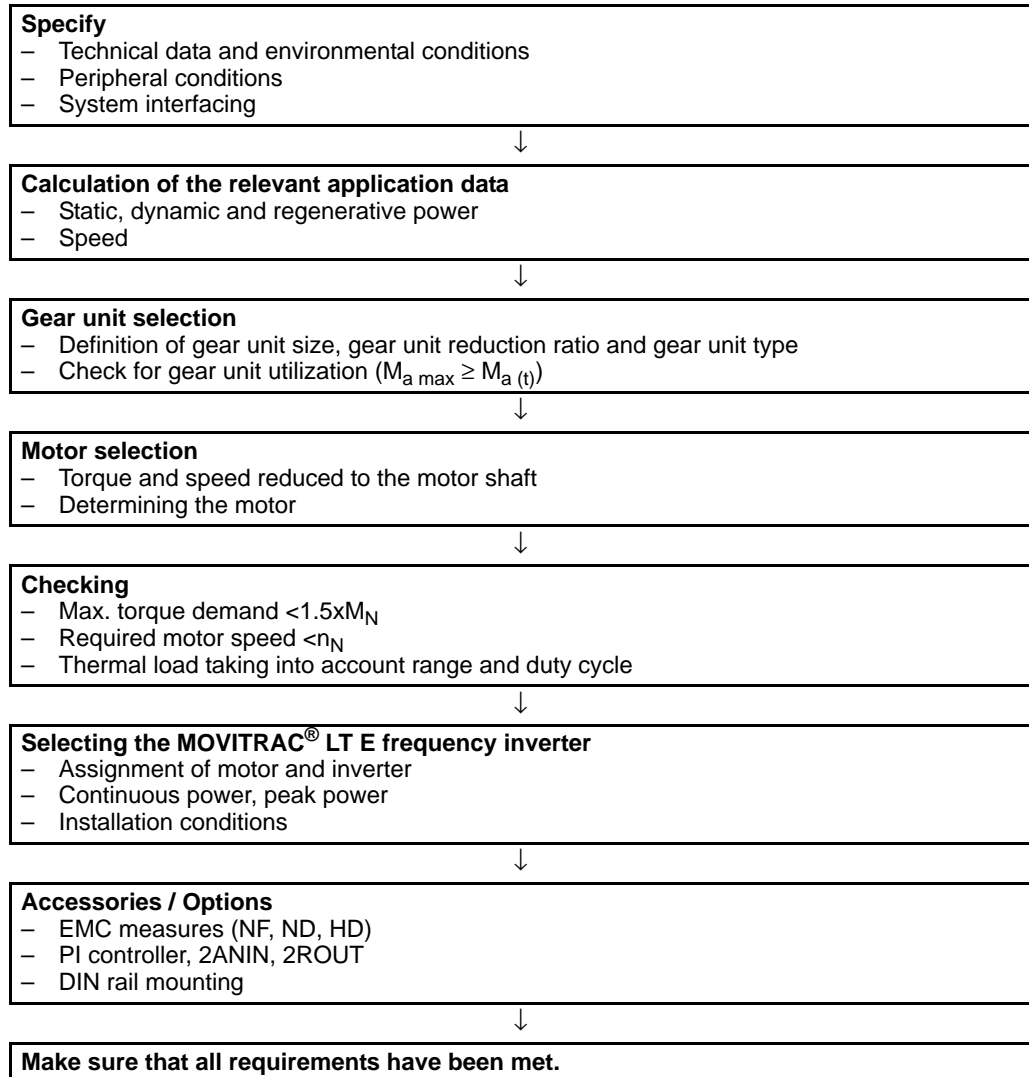

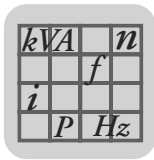

Select a motor

Inverter → motor combinations

6.2 Inverter → motor combinations

The tables below are an extract from the SEW-EURODRIVE catalogs for gearmotors.

Motors for 220 V ... 240 V, 50 / 60 Hz connection

SEW-EURODRIVE Motor type	Motorpower		Motor rated speed	Inverter type MC LT E -201-00 MC LT E -2B1-00
	[kW]	[hp]		
DT71D4	0.37	(0.5)	1380	0004
DT71D4 NEMA	0.37	(0.5)	1700	0004
DT80K4	0.55	(0.75)	1360	0008
DT80K4 NEMA	0.55	(0.75)	1700	0008
DT80N4	0.75	(1.0)	1380	0008
DT80N4 NEMA	0.75	(1.0)	1700	0008
DT90S4	1.1	(1.5)	1400	0015
DT90S4 NEMA	1.1	(1.5)	1740	0015
DT90L4	1.5	(2.0)	1410	0015
DT90L4 NEMA	1.5	(2.0)	1720	0015
DV100M4	2.2	(3.0)	1410	0022
DT100LS4 NEMA	2.2	(3.0)	1720	0022

Motors for 380 V ... 480 V, 50 / 60 Hz connection

SEW-EURODRIVE Motor type	Motorpower		Motor rated speed	Inverter type MC LT E -501-00 MC LT E -5A1-00
	[kW]	[hp]		
DT80K4	0.55	(0.75)	1360	0008
DT80K4 NEMA	0.55	(0.75)	1700	0008
DT80N4	0.75	(1.0)	1380	0008
DT80N4 NEMA	0.75	(1.0)	1700	0008
DT90S4	1.1	(1.5)	1400	0015
DT90S4 NEMA	1.1	(1.5)	1740	0015
DT90L4	1.5	(2.0)	1410	0015
DT90L4 NEMA	1.5	(2.0)	1720	0015
DV100M4	2.2	(3.0)	1410	0022
DV100LS4 NEMA	2.2	(3.0)	1720	0022
DV100L4	3.0	(4.0)	1400	0040
DV100L4 NEMA	3.7	(5.0)	1680	0040
DV112M4	4.0	(5.4)	1420	0040
DV112M4 NEMA	4.0	(5.4)	1730	0040



A		P	
Accessories.....	7, 19	P-19 Digital inputs	18
Application environment.....	5	Parameters	
Applications.....	7	<i>Extended</i>	17
		<i>Standard</i>	16
C		Physical dimensions.....	12
Conformance.....	11	PI Controller	24
		Power, output	9
D		Product designation	8
Dimensions	12	Product overview.....	7
<i>Non vented metal housing</i>	13	Project planning flowchart	25
DIN rail mounting kit.....	22	Protection features	11
Display	14		
		R	
E		Rail mounting kit, DIN	22
Environment, application.....	5		
Environmental	11	S	
Explanation of symbols	4	Safety Notes.....	6
Explosion-proof areas	5	Second analog input	
Extended parameters.....	17	<i>Analog input</i>	22
		Second relay output	
I		<i>Relay output</i>	23
Important Notes.....	4	Select a motor	25
Input filter	19	Servicing	6
Input voltage ranges.....	8	Signal terminals overview	15
Installation.....	6	Specifications	8
Interface, user	14	Standard parameters	16
		Startup.....	6
K		Symbols, explanation	4
Keypad.....	14		
		T	
M		Technology.....	7
Mains supply compatibility	7		
Markets	7	U	
Motor and inverter selection.....	26	User interface.....	14
Motor selection.....	25		
		V	
O		Voltage ranges, input	8
Operation	6		
Output indicators.....	21	W	
Output power.....	9	Waste disposal.....	5
Overload.....	11		
Overview, product	7		

How we're driving the world

With people who think fast and develop the future with you.



With a global presence that offers responsive and reliable solutions. Anywhere.

With a worldwide service network that is always close at hand.

With drives and controls that automatically improve your productivity.



With innovative technology that solves tomorrow's problems today.

With comprehensive knowledge in virtually every branch of industry today.



With online information and software updates, via the Internet, available around the clock.

With uncompromising quality that reduces the cost and complexity of daily operations.

SEW-EURODRIVE
Driving the world



SEW-EURODRIVE GmbH & Co KG
P.O. Box 3023 · D-76642 Bruchsal / Germany
Phone +49 7251 75-0 · Fax +49 7251 75-1970
sew@sew-eurodrive.com

→ www.sew-eurodrive.com